

---

# PXle-7862

# Features

---

2022-10-24

# Contents

NI PXIe-7862 User Manual.....	3
Hardware Overview.....	3
Pinout.....	3
Connectivity Options.....	5
Analog Input.....	5
Analog Output.....	7
Digital I/O.....	7
Field Wiring Considerations.....	9
+5 V Power Source.....	9
NI Services.....	10

# NI PXIe-7862 User Manual

This document provides compliance, pinout, connectivity, mounting, and power information for the NI PXIe-7862.

## Hardware Overview

The following high-level block diagram represents the NI PXIe-7862.

Figure 1. NI PXIe-7862 Block Diagram

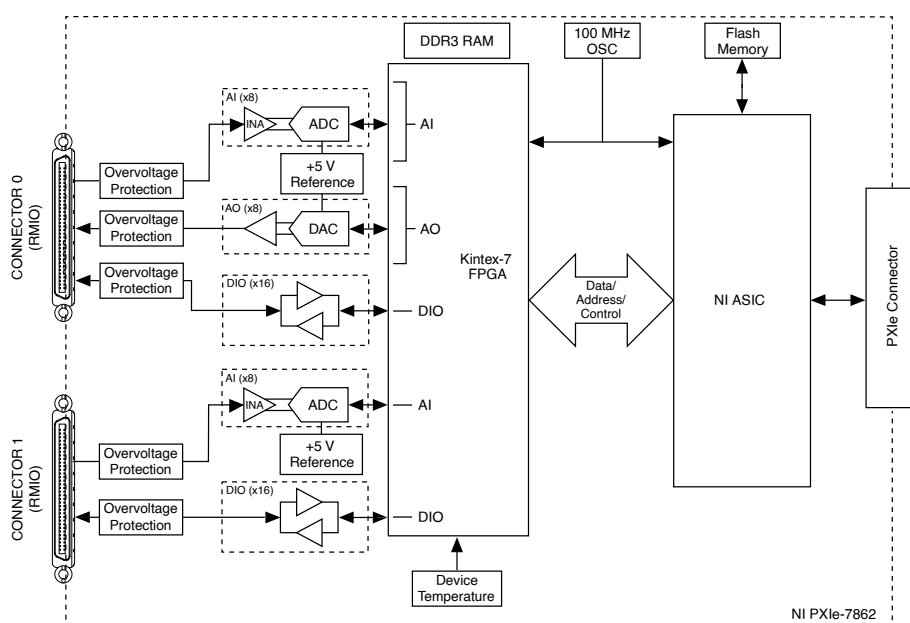

## Pinout

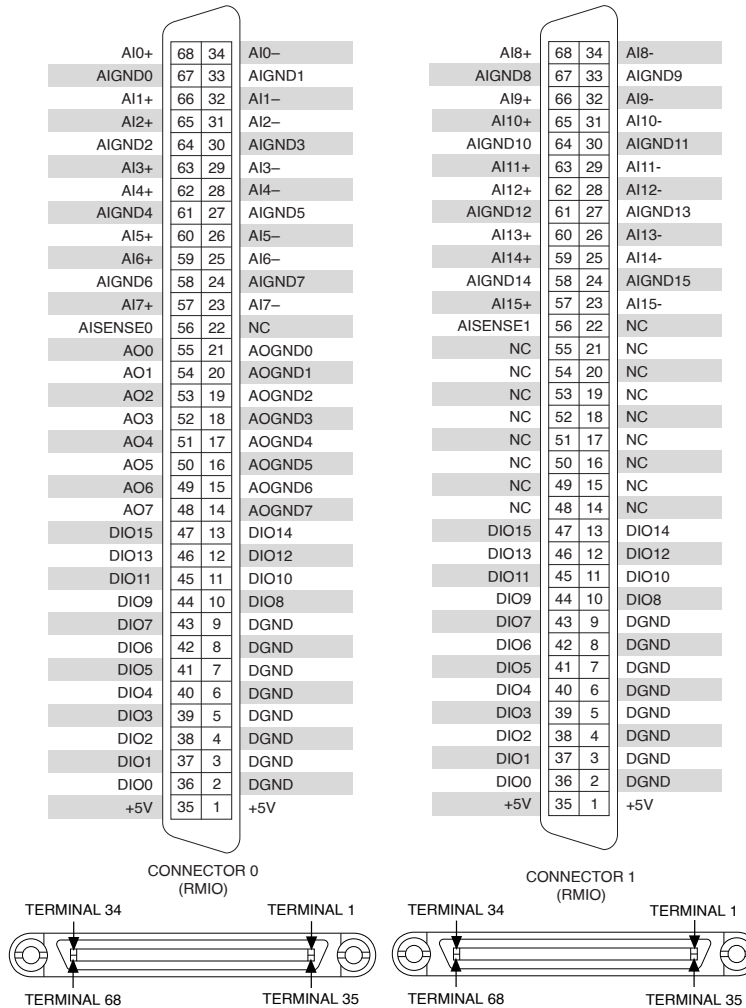

Signal	Description
AI+	Positive analog input signal connection
AI-	Negative analog input signal connection
AISENSE	Reference connection for NRSE measurements
AIGND	Ground reference for the analog input signal
AO	Analog output signal connection
AOGND	Ground reference for the analog output signal
DIO	Digital input/output signal connection
DGND	Ground reference for the digital signal
GND	Ground connection
Supply (+5 V <sub>out</sub> )	5 V power output connection for external devices

Signal	Description
NC	No connection

Table 1. NI PXIe-7862 Signal Descriptions

The NI PXIe-7862 is protected from overvoltage and overcurrent conditions.

**Note** Refer to the **NI PXIe-7862 Specifications**, available at [ni.com/manuals](http://ni.com/manuals) for more information.

**Note** The pinout label on the lid of the SCB-68A accessory is incompatible with the NI PXIe-7862. Refer to the **NI 78xxR Pinout Labels for the SCB-68A**, available at [ni.com/manuals](http://ni.com/manuals) for the compatible pinout labels.

## Connectivity Options

Use the following connection accessories and cables to access the signals on the I/O connectors.

Connector Type	Accessory	Description	NI Part Number
RMIO	NI SCB-68A	Noise Rejecting, Shielded I/O Connector Block	782536-01
	NI SHC68-68-RMIO	RMIO Shielded Cable, 68 pin D-Type to 68 pin VHDCI (1 m)	189588-01
		RMIO Shielded Cable, 68 pin D-Type to 68 pin VHDCI (2 m)	189588-02

Table 2. Connection Accessories and Cables

## Analog Input

The NI PXIe-7862 provides connections for 16 AI channels. Each channel has an AI+ pin, AI- pin, and AIGND pin to which you can connect both single-ended or differential voltage signals. Use the AISENSE pin to connect non-referenced single-ended signals.

## Connecting Single-Ended Voltage Signals

To connect referenced single-ended voltage signals to the NI PXIe-7862, you must connect the voltage ground signal to AI GND in order to keep the common-mode voltage in the specified range.

Figure 2. Connecting Referenced Single-Ended Signals to the NI PXIe-7862

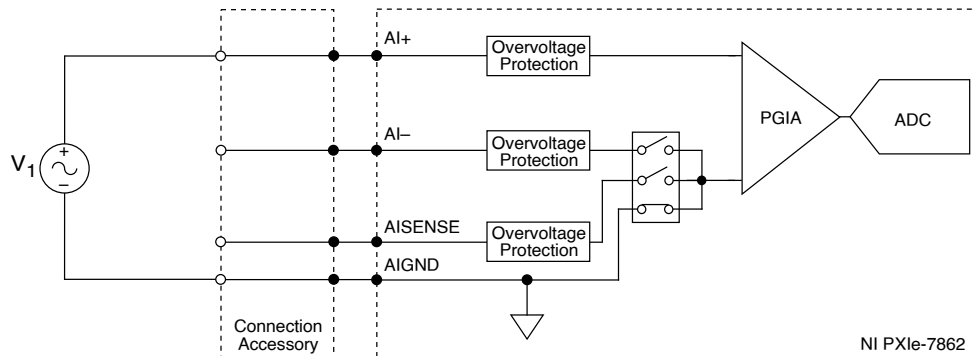

To connect non-referenced single-ended voltage signals to the NI PXIe-7862, you must connect the voltage ground signal to AI SENSE in order to keep the common-mode voltage in the specified range.

Figure 3. Connecting Non-Referenced Single-Ended Signals to the NI PXIe-7862

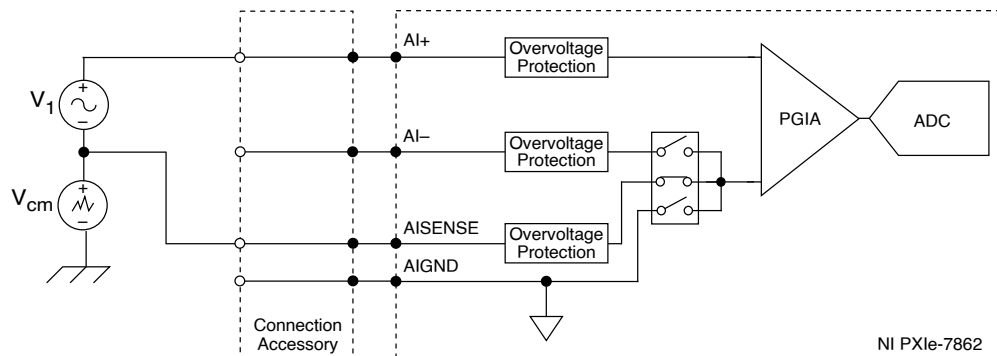

## Connecting Differential Voltage Signals

You can connect grounded or floating differential signal sources to the NI PXIe-7862. Connect the positive voltage signal to the AI+ and the negative voltage signal to AI-. To connect grounded differential signals to the NI PXIe-7862, you must also connect the signal reference to AI GND.

Figure 4. Connecting Grounded Differential Signals to the NI PXIe-7862

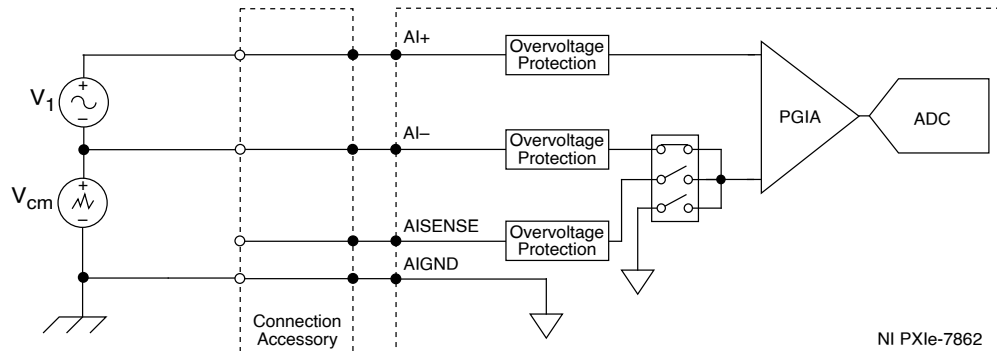

To connect floating differential signals to the NI PXIe-7862, you must connect the negative and positive signals to AI GND through 1 M $\Omega$  resistors to keep the voltage within the common-mode voltage range. If the voltage source is outside the common-mode voltage range, the NI PXIe-7862 does not read data accurately.

Figure 5. Connecting Floating Differential Signals to the NI PXIe-7862

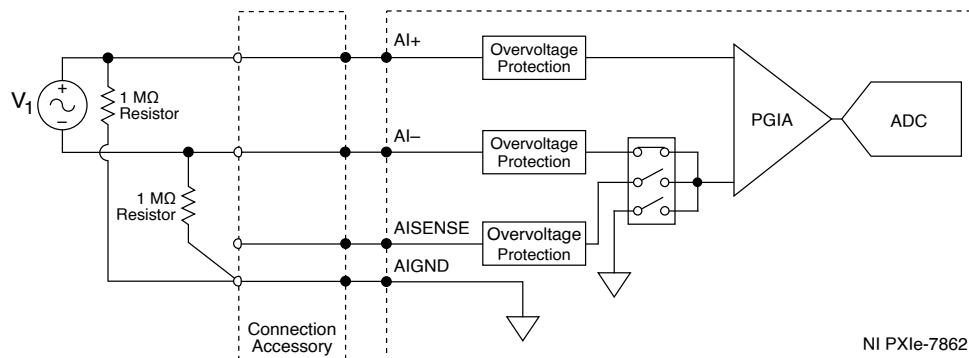

## Analog Output

The NI PXIe-7862 provides connections for eight analog output channels. Each channel has an AO pin and AOGND pin to which you can connect a load.

Figure 6. Connecting a Load

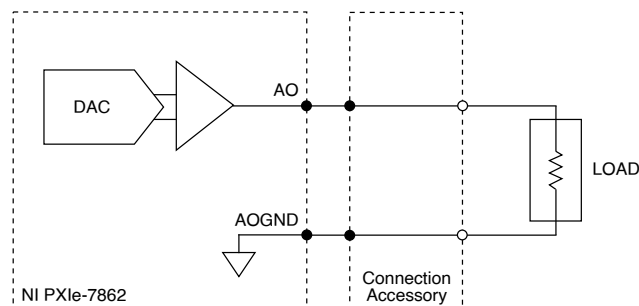

## Digital I/O

The NI PXIe-7862 provides connections for 32 digital input/output (DIO) channels. Connector 0 and Connector 1 each contains 16 low-speed channels that can run up to 10 MHz signal frequencies. Each connector has a fixed logic level of 3.3 V. You can configure each channel as input or output.

Figure 7. Connecting to the DIO Channels

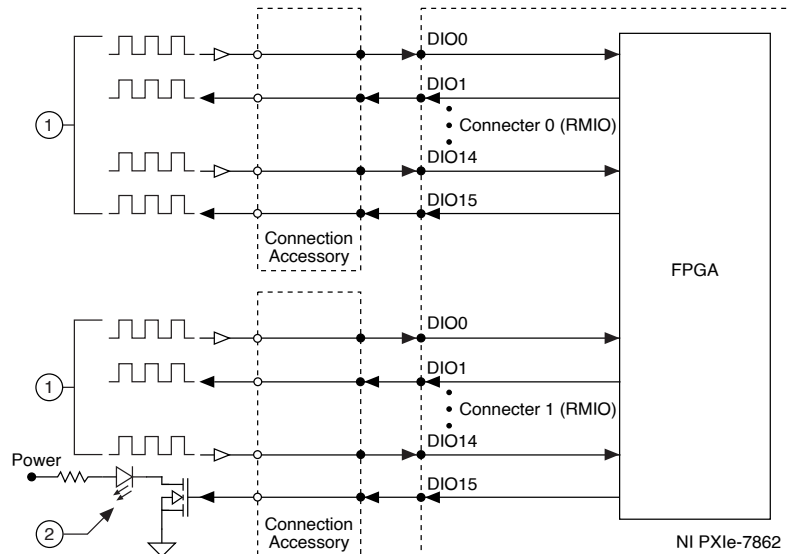

1. Low-speed signal frequencies up to 10 MHz with logic levels configured as 3.3 V.
2. LED

The DIO channels, which have overvoltage and undervoltage protection as well as over current protection, connect to the FPGA. Refer to the device specifications on [ni.com/manuals](http://ni.com/manuals) for more information about the maximum voltage and current.

When the system powers on, the DIO channels are set as input low with pull-down resistors. To set another power-on state, you can configure the NI PXIe-7862 to load a VI when the system powers on. The VI can then set the DIO lines to any power-on state. Visit [ni.com/info](http://ni.com/info) and enter RSeries\_PowerUpStates to learn more about configuring the power-up states for the NI PXIe-7862.

All the DIO channels on each connector are routed with a 50  $\Omega$  characteristic trace impedance. Route all external circuitry with a similar impedance to ensure best signal quality. NI recommends performing signal integrity measurements to test the

affect of signal routing with the cable and connection accessory for your application.

## Field Wiring Considerations

Environmental noise can seriously affect the measurement accuracy of the device if you do not take proper care when running signal wire between signal sources and the device. The following recommendations mainly apply to AI signal routing to the device, as well as signal routing in general.

Take the following precautions to minimize noise pickup and maximize measurement accuracy:

- Use differential AI connections to reject common-mode noise.
- Use individually shielded, twisted-pair wires to connect AI signals to the device. With this type of wire, the signal attached to the positive and negative inputs are twisted together and then covered with a shield. You then connect this shield only at one point to the signal source ground. This kind of connection is required for signals traveling through areas with large magnetic fields or high electromagnetic interference.
- Route signals to the device carefully. Keep cabling away from noise sources, such as video monitors and analog signals.

Use the following recommendations for all signal connections to the NI PXIe-7862:

- Separate NI PXIe-7862 signal lines from high-current or high-voltage lines. These lines can induce currents in or voltages on the NI PXIe-7862 signal lines if they run in parallel paths at a close distance. To reduce the magnetic coupling between lines, separate them by a reasonable distance if they run in parallel or run the lines at right angles to each other.
- Do not run signal lines through conduits that also contain power lines.
- Protect signal lines from magnetic fields caused by electric motors, welding equipment, breakers, or transformers by running them through special metal conduits.
- To minimize signal-to-signal skew within each digital channel, maintain signal lines' length within 1 inch of difference.

## +5 V Power Source

Use the +5 V terminals on the I/O connector supply +5 V referenced to DGND to power external circuitry.

**Caution** Never connect the +5 V power terminals to analog or digital ground or any other voltage source on the NI PXIe-7862 or any other device. Doing so can damage the device and the computer. National Instruments is not liable for damage resulting from such a connection.

The power rating is 4.75 to 5.1 V DC at 0.5 A per connector.

## NI Services

Visit [ni.com/support](https://ni.com/support) to find support resources including documentation, downloads, and troubleshooting and application development self-help such as tutorials and examples.

Visit [ni.com/services](https://ni.com/services) to learn about NI service offerings such as calibration options, repair, and replacement.

Visit [ni.com/register](https://ni.com/register) to register your NI product. Product registration facilitates technical support and ensures that you receive important information updates from NI.

NI corporate headquarters is located at 11500 N Mopac Expwy, Austin, TX, 78759-3504, USA.